

EL-FLOW[®] DIGITAL MASS FLOW METERS AND CONTROLLERS

INTRODUCTION

Bronkhorst High-Tech B.V., manufactures the largest variety of thermal Mass Flow Meters and Controllers for gases and liquids. Instruments of the EL-FLOW[®] series are now available in a completely new digital version.

In some applications there are more requirements for a modern instrument than analog based technology can offer. Examples of these requirements are self diagnostics, alarm and counter functions, digital communication and remotely adjustable control settings. These requirements can only be met with a digital based instrument. Therefore, Bronkhorst High-Tech B.V. developed this new instrument that offers you more features than the analog based design.

DESCRIPTION

The digital Mass Flow Meters and Controllers are based on new digital electronics where the analog sensor signal is sent directly to a micro processor. By doing so, optimum signal stability and accuracy is achieved. An integral alarm function continuously checks the difference between the setpoint- and the measured value. If, for example, the supply pressure of a Mass Flow Controller drops and therefore the flow can no longer be controlled, the instrument gives a warning. In addition the instrument runs a self diagnostics routine, and controller settings can be remotely adjusted with a handterminal or a computer via FLOW-BUS, Bronkhorst Hi-Tec's RS-485 based fieldbus.

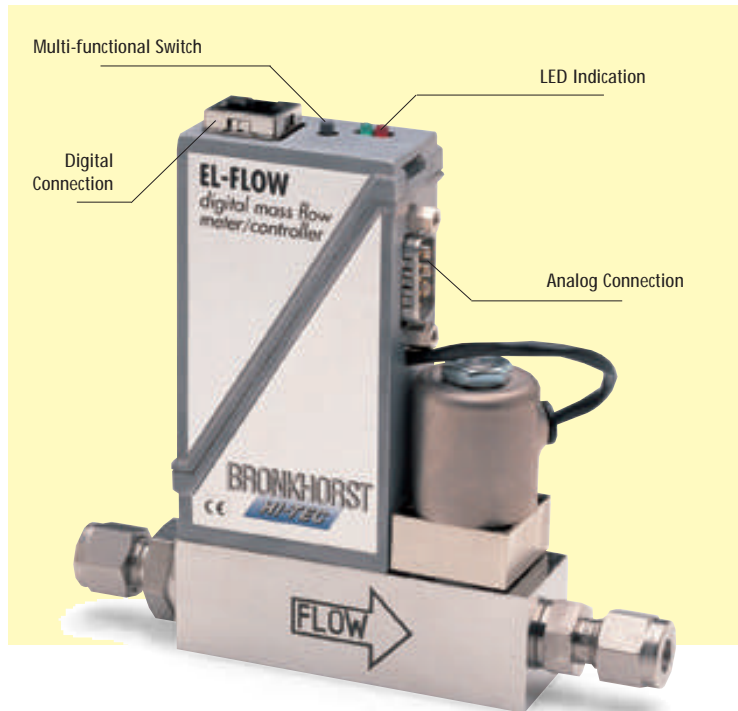

Model F-201C Digital Mass Flow Controller

In these instruments both analog in- and output signals and digital communications are possible at the same time. Thanks to this feature it is very easy to replace analog instruments with digital instruments in an existing installation. The digital features of the new instrument can be selected with a multi-functional switch on the instrument, with a handterminal or a computer via FLOW-BUS.

FEATURES

- high accuracy with storage of up to 8 calibration curves
- fully interchangeable with analog instruments
- RS-485 digital communication and analog signals
- fast response controller
- high stability and repeatability
- alarm and counter functions
- single rail power supply: +15 Vdc or +24 Vdc



DESCRIPTION

Functional description

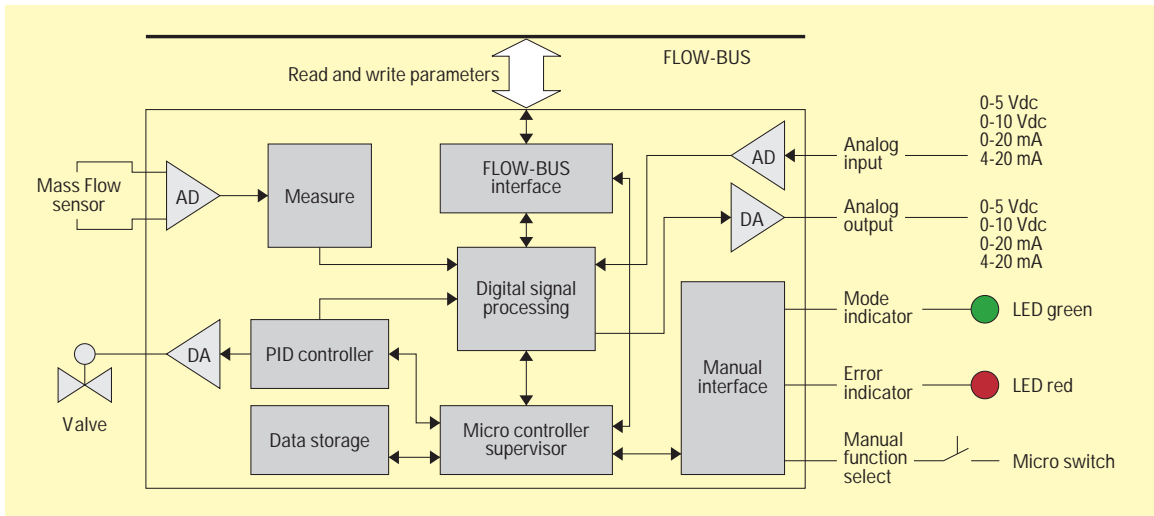

The micro controller has a peripheral circuitry for measuring, controlling, external in- and output signals and digital communication. It is the heart of the instrument and constantly performs self diagnostics.

The sensor signal is directly converted to a digital signal which enables digital processing, for example the calculation of a polynomial function for high accuracy. The measured and processed values can be output through an analog interface or through a digital communication line. Digital instruments have many parameters for settings, signal processing and controlling. These parameters can only be read or changed through digital communication. The functions of the instrument are also accessible through digital communication, for a selection of functions there is a local switch and a local LED indication.

Other digital FLOW-BUS instruments

Based on the same digital configuration as the EL-FLOW® digital Mass Flow Meters and Controllers, Bronkhorst High-Tech also offers digital versions of the following product series:

- **LOW- Δ P-FLOW** : Mass Flow Meters and Controllers for low pressure drop applications
- **EL-PRESS** : Pressure Meters and Controllers

The unique combination of the digital instruments of these three product series offers a complete digital process system. More information about the other product lines is available at your distributor.

Handterminal

Based on the E-7000 series a hand-terminal is developed for local readout and control for digital instruments. In big and complex automated systems it is often the case that the application software is only designed to control the application. Troubleshooting and the selection of other specific functions or parameters of digital instruments can be performed by the handterminal. The handterminal is a part of the FLOW-BUS system and it is possible to control the system separately from the application software.



SPECIFICATIONS AND CHARACTERISTICS

General specifications

Accuracy	: $\pm 0,5$ % of reading plus $\pm 0,1$ % of FS (under operating conditions)
Flow ranges (based on N ₂)	: from 3 ml _r /min up to 1250 l _r /min
Control range	: turndown 2...100%, automatic valve shut off at setpoint < 1%
Operating temperature	: - 10...+ 70°C
Settling time	: 1 second, typical (faster on request)
(as per Semi E17-91)	
Warm-up time	: 20 min. for best accuracy; 2 min. for accuracy ± 2 % of full scale
Control stability	: < $\pm 0,1$ % FS
Repeatability	: < $\pm 0,2$ % of rate
Attitude sensitivity	: max. error at 90° off horizontal 0,015% at 1 bar, typical N ₂
Vibration sensitivity	: negligible
Pressure sensitivity	: 0,1 %/bar typ. N ₂ / 0,01 %/bar typ. H ₂
Temperature sensitivity	: off zero - 0,05 % of FS/°C (as per Semi E18-91)
Leak integrity	: each unit is tested to meet < 2 x 10 ⁻⁹ mbar-l-s ⁻¹ He additionally a pressure test at 1,5 times the max. stated operating pressure is performed (as per Semi E19-90)

Mechanical specifications

Construction material	: SS 316L (other on request)
Seat materials	: Viton, EPDM, elastomeric PTFE (other on request)
Surface quality	: Ra 0,2...0,6
Process connections	: compression type, face seal (other on request)

Electrical characteristics

Power supply	: + 15 Vdc or + 24 Vdc to be advised
Consumption electronics	: 100 mA
Consumption valve	: 250 mA (max.)
Power supply sensitivity	: ± 10 % change in 15V / 24V - no effect
Output signal	analog : 0...5 (10) Vdc; 2 kOhm min. load : 0 (4)...20 mA (sourcing); 375 Ohm max. load digital : RS-485 (FLOW-BUS)
Command signal	analog : 0...5 (10) Vdc; 424 kOhm load : 0 (4)...20 mA (sinking); 250 Ohm load digital : RS-485 (FLOW-BUS)
Electrical connection	analog : male, 9-pin sub-D connector digital : female, 8-pin RJ45 modular jack connector
EMI protection	: completely shielded electronics
RFI	: CE approved design

Digital and RS485 characteristics

Multi-functional switch for:	• auto zeroing of sensor signal • restore option for factory settings • instrument reset • automatic installation on FLOW-BUS • remote installation on FLOW-BUS
Two LED indication	: for mode and error messages
Diagnoses capabilities	: self-test
Alarm functions	• response alarm • minimum and maximum flow alarm
Counter functions	: totalizer and batch counter (accuracy ≤ 1 %)
Data storage	: non-volatile > 10 years
AD converter for sensor	: 18 bit (adjustable)
Bus load	: 1/10 of normal; up to 120 transceivers on the bus

Model number identification EL-FLOW® digital

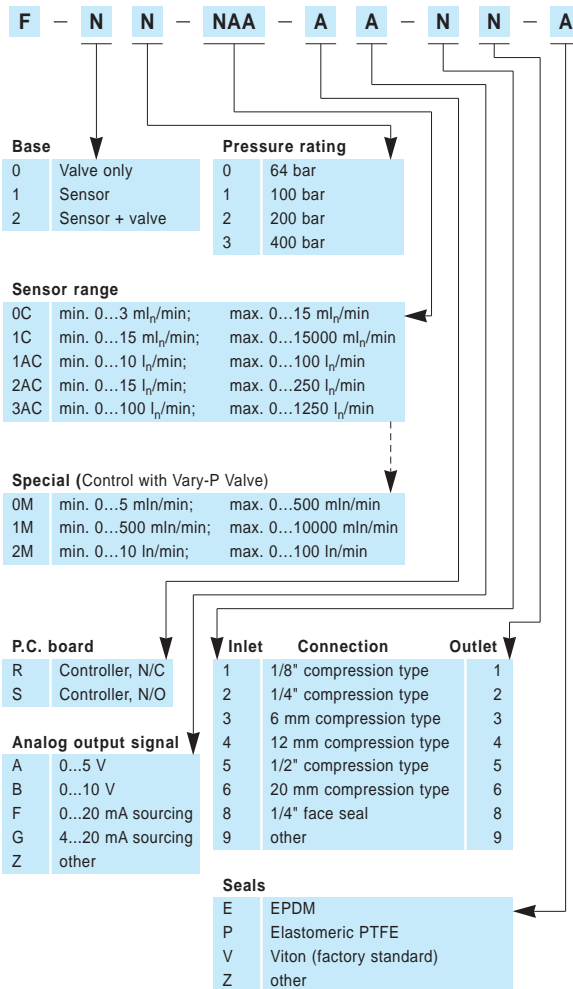

EXAMPLES AND FEATURES

FLOW-BUS configuration examples:

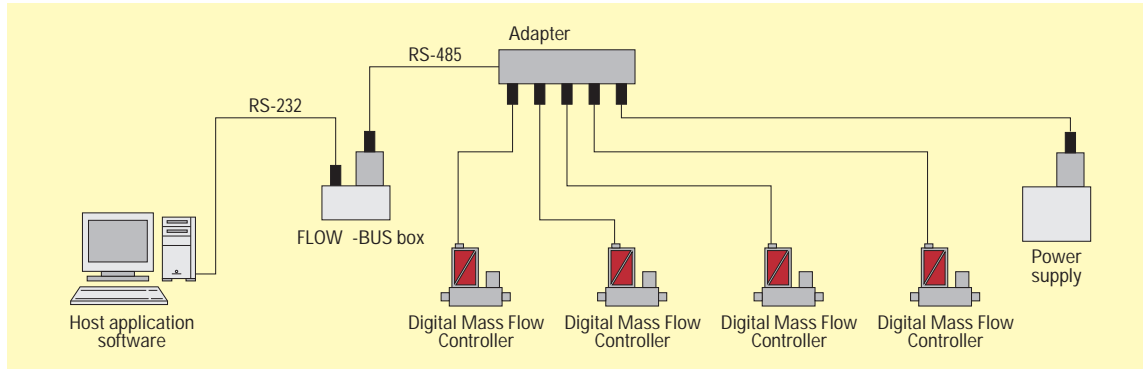

Configuration with personal computer

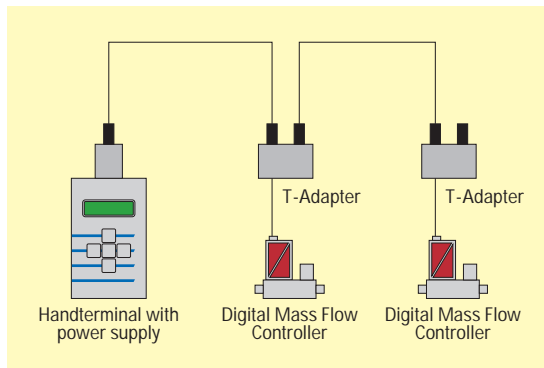

Configuration with handterminal

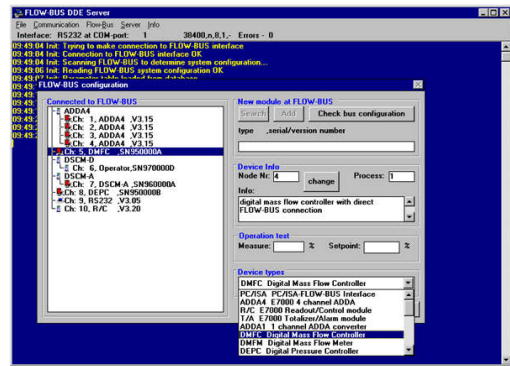

DDE-server software for dataexchange with application software

FLOW-BUS features:

- protocol protected fieldbus system to prevent software- or communication errors.
- fieldbus for 120 channels.
- high speed communication: Baudrate 187,5 kBaud
- long distance RS-485 daisy-chain connection, up to 600 meter.
- maximum bus length 2,5 km.
- digital readout series E-7000 / E-7001.
- RS-232 or PC-ISA interfaces available for computer communication.
- PROFIBUS DP interface available, other interfaces on request.

FLOW-BUS software support for personal computer (IBM compatible):

- DDE server for parameter exchange between FLOW-BUS and process control and visualisation software under MS Windows. (e.g. Visual Basic applications, SCADA packages such as Intouch, Labview, Windmill, Fix).
- library with routines for MS Windows, FLOW-BUS.DLL.
- application software (on request).

BRONKHORST
HI-TEC

Nijverheidsstraat 1a, 7261 AK Ruurlo, Netherlands
Telephone: +31 573 458800, telefax: +31 573 458800,
Internet: www.bht.nl/bht, E-mail: Sales@BHT.NL

Distr.:

E.DIG.0398.C